

**THE CORPORATION OF THE
TOWNSHIP OF EAST ZORRA-TAVISTOCK**

COUNTY OF OXFORD

BY-LAW # 2008-24

BEING a By-law to provide for the requirements of owners of privately owned swimming pools to erect fences and enclosures within the Township of East Zorra-Tavistock.

WHEREAS Section 11 (1) 7 of the Municipal Act, 2001 S.o. 2001, c.25, as amended (hereinafter the "Municipal Act") provides that a municipality may pass by-laws within the sphere of jurisdiction entitled Structures, including fences and signs;

AND WHEREAS the Council of the Municipality of the Township of East Zorra-Tavistock deems it necessary to regulate and require owners of privately owned outdoor swimming pools to erect and maintain fences and gates around such pools, and for prescribing the height and description of, and manner of erecting and maintaining such fences and gates;

NOW THEREFORE THE COUNCIL OF THE TOWNSHIP OF EAST ZORRA-TAVISTOCK ENACTS AS FOLLOWS:

1. Definitions for the purposes of this By-law:
 - 1.1. "swimming pool" shall be defined to mean any body of water, located on private property, having a depth in excess of two (2) feet at any point and contained by either concrete, metallic or vinyl means, which is intended for the use of swimming, diving, or bathing but shall not include a farm pond nor a farm watering trough to be used exclusively for the watering of livestock.
 - 1.2. "Temporary pool" is defined as a swimming pool which is designed to be removed periodically, is for temporary or seasonal use, and which is not erected from October to February.
2. The owners of outdoor swimming pools shall be required to construct and maintain around such pool an approved fence of closed board or chain link design or other design approved by the Building Inspector of the Township of East Zorra-Tavistock, such fence to be at least four (4) feet in height. The wall of a building may be substituted for a fence provided that the swimming pool is fenced on all other sides by an approved fence under the terms of this By-law and provided further that any doors in such building are equipped with self-closing locks or latching devices located at least four (4) feet from the bottom of such door and provided further that

the building is continuously occupied or that all doors in the building are locked when the building is not so occupied.

3. Adequate Fencing:

3.1. The fence surrounding such swimming pool may contain a gate provided that the gate provides equivalent protection to the fence, is of the same height, and is equipped with a self-latching device or lock located at least four (4) feet from the ground level and provided further that the gate is maintained in a locked condition unless being used for ingress to or egress from the pool area.

3.2. A fence or its equivalent forming part of an enclosure, shall be permitted to have exposed structural or other members or parts thereof that may facilitate climbing the outside of the enclosure provided that minimum clear vertical distance between any such members, or parts thereof, is four (4) feet and, regardless of the location of such members, where this minimum four (4) feet vertical dimension is maintained the least dimension of any opening through such fence may be increased to not more than that required to prevent the passage of a spherical object having a diameter of 3.6 inches.

3.3. In the event that the pool is constructed above the level of the ground the walls of the pool shall be at least four (4) feet in height and in the event that they are surrounded by a deck the deck shall be at least four (4) feet in height or walls shall be constructed enclosing the same to at least a height of four (4) feet above the ground level.

3.4. In the case of a swimming pool constructed above ground level the stairway or access to the pool or deck thereof shall be enclosed by a fence at least four (4) feet in height and if such fence has a gate for access it shall be constructed in accordance with paragraph 3.1 as set out herein.

3.5. Each fence constructed under the terms of this By-law shall be located at least four (4) feet from the swimming pool provided that the fence may be located closer to the pool with the authorization of the Building Inspector of the Township of East Zorra-Tavistock.

3.6. In addition to the provisions set out above, the provisions contained in Schedule "A" attached hereto and forming part of this bylaw shall also apply.

4. Indoor Swimming Pools:

4.1. Each indoor swimming pool within the Township shall be designed in accordance with Part 4 of the Ontario Building Code to safely withstand all dead and live loads.

4.2. All openings to indoor swimming pools shall be protected with doors or other approved closures, approved by the Building Inspector and shall contain self-closing and latching devices and locks located at least four (4) feet, six (6) inches from the bottom of such closure.

5. Building Permit

5.1. All persons constructing a swimming pool, except temporary pools, shall be required to obtain a Building Permit. Swimming pools, except temporary pools, may not be erected within the Township of East Zorra-Tavistock until a Building Permit has been obtained. The commencement of excavation for an inground or aboveground swimming pool shall be deemed for the purposes of this by-law to be the erection of a swimming pool within the Township of East Zorra-Tavistock.

5.2. Temporary pools do not require a building permit, but are subject to all other provisions of this bylaw.

6. Hot tubs

6.1. Hot tubs that are adequately secured by a cover equipped with a locking device and locked when not in use are exempt from Section 2.

7. Any person who contravenes any of the provisions of this by-law is guilty of an offence and upon conviction is liable to a fine or penalty for each offense established pursuant to the Provincial Offences Act, R.S.O. 1990, c. P23.

8. That By-law #14-77, as amended, is hereby repealed.

9. This by-law shall be called the "The Pool Fencing By-law".

READ A FIRST AND SECOND TIME THIS 21st DAY OF MAY 2008

READ A THIRD TIME AND FINALLY PASSED THIS 21st DAY OF MAY 2008

"Original Signed by Don McKay"

Don McKay, Mayor

"Original Signed by Jeff Carswell"

Jeff Carswell, Clerk

Schedule "A"

Note: This sheet is intended as a guide to the information required when submitting drawing of a swimming pool enclosure. It shall also form part of this by-law as specification to the type of fencing allowed.

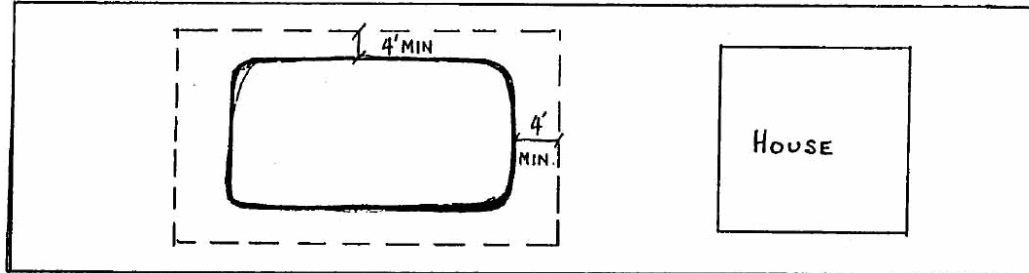

Plot Plan (Example)

Detail of Fence Construction

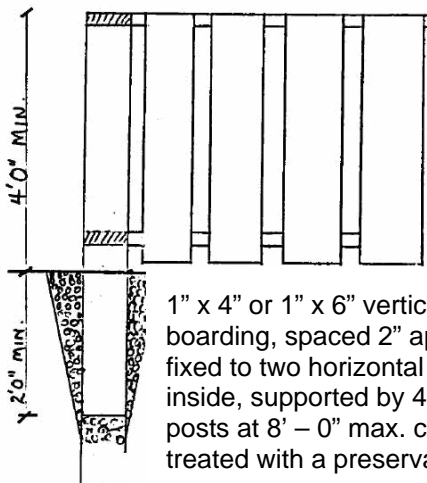

1" x 4" or 1" x 6" vertical boarding, spaced 2" apart and fixed to two horizontal rails on inside, supported by 4"x 4" cedar posts at 8' - 0" max. centres, treated with a preservative.

If the difference between climbable parts (horizontal supports) is 48" or more the openings between fence boards can be up to 3.6"

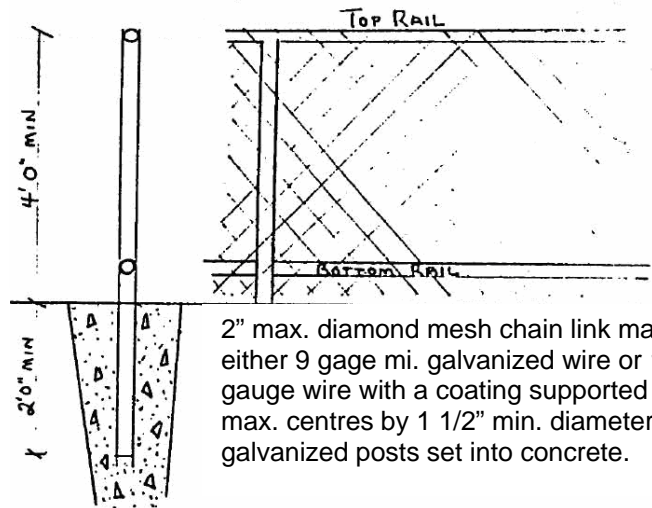

2" max. diamond mesh chain link made of either 9 gage mi. galvanized wire or 12 gauge wire with a coating supported at 10'-0" max. centres by 1 1/2" min. diameter galvanized posts set into concrete.

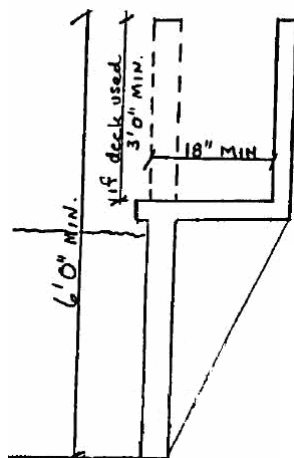

A 4' high min. non-climbable enclosure to be provided around pool access with a 4' high gate equipped with self-closing and self-latching device.

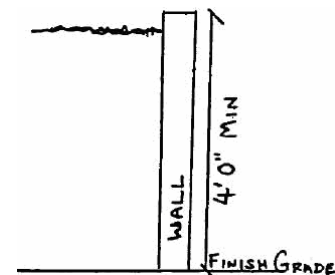

NOTE: Above ground pools do not require a fence, unless the wall of the pool is less than four (4) feet above finish grade