

**THE CORPORATION OF THE
TOWNSHIP OF EAST ZORRA-TAVISTOCK
COUNTY OF OXFORD**

**BY-LAW # 1996 - 32
*As amended by By-law #2006-41***

BEING a by-law to establish Fire Routes within the Township of East Zorra-Tavistock.

WHEREAS pursuant to Section 210, p.52 of the Municipal Act, R.S.O. 1990, the Council of a municipality may pass a by-law establishing fire routes within the municipality;

AND WHEREAS the Council of the Corporation of the Township of East Zorra-Tavistock deems it necessary and expedient to establish such fire routes;

NOW THEREFORE the Council of the Corporation of the Township of East Zorra-Tavistock ENACTS AS FOLLOWS:

1. SHORT TITLE

1.1 This by-law may be cited as the "Fire Routes By-law".

2. DEFINITIONS

2.1 MOTOR VEHICLE - means any automobile, motorcycle or other vehicle propelled or driven otherwise than by muscular power.

2.2 PRIVATE PROPERTY - means property owned or occupied by a person or persons other than the Corporation of the Township of East Zorra-Tavistock, or any local board thereof, and includes property owned or occupied by a corporation.

3. GENERAL PROVISIONS

3.1 DESIGN STANDARDS FOR ROUTES - shall be as provided in the Ontario Building Code, as amended.

3.2 LOCATION OF ROUTE - shall be as provided in the Ontario Building Code, as amended.

3.3 FIRE ROUTE - PARKING PROHIBITED - the private property or portion thereof described in Schedule "A" forming part of this by-law is hereby designated a fire route along which no parking of vehicles shall be permitted.

3.4 VEHICLE - PARKING / STANDING ON FIRE ROUTE PROHIBITED - no person shall park or leave standing a motor vehicle on any fire route on private property designated as such by this by-law.

- 3.5 **CONTRAVENTION - LIABILITY/EXCEPTION OF VEHICLE OWNER** - the Owners of a motor vehicle parked or left standing on any fire route on private property designated as such in this by-law is liable, as is the driver of such motor vehicle, to any penalty provided in this by-law unless, at the time of the offence, the motor vehicle was in the possession of a person other than the Owners or his/her chauffeur without the Owners's consent.
- 3.6 **AUTHORIZATION TO ISSUE PARKING VIOLATION TAGS** - a peace officer or constable or an officer appointed for the carrying out of the provisions of the Highway Traffic Act or an officer appointed for the enforcement of municipal by-laws may issue and attach to a motor vehicle found parked in contravention of this by-law a Township of East Zorra-Tavistock parking violation tag alleging that the provisions of this by-law have been contravened.
- 3.7 **AUTHORIZED REMOVAL OF VEHICLES IN CONTRAVENTION** - a peace officer or a constable or an officer appointed for the carrying out of the provisions of the Highway Traffic Act or an officer appointed for the enforcement of municipal by-laws may, upon discovery of a motor vehicle parked or left contrary to Section 3.4, cause such vehicle to be moved from such fire route and taken to and placed in a suitable storage place, and all costs and charges for removing, care and storage thereof, if any, shall be a lien upon the vehicle.
- 3.8 **SIGNS**
- 3.8.1 **Mounting Height** 3 metres measured from the top limit of the sign to the grade of the Fire Route surface adjacent to the Fire Route sign.
- 3.8.2 **Spacing Between Signs** not more than 30 metres (100 ft) between signs located on the same side of the Fire Route and spaced such that at least 1 sign is clearly visible and lettering is legible from all locations within the Fire Route.
- 3.8.3 **Location of Signs**
- a) Fire Routes greater than 6.1 metres in width - one side of the Fire Route.
 - b) Fire Routes 6.1 metres or less in width - both sides of the Fire Route.
- 3.8.4 **Setback from the Fire Route**
- a) Where a curb or equivalent edge treatment is not provided to define the edge of the Fire Route - minimum 3.0 metres (10 ft) and maximum 4.0 (13 ft) to any part of the sign.
 - b) Where a curb or equivalent edge treatment is provided to define the edge of the Fire Route - minimum 0.3 metres (1

- ft) and maximum 1.0 metre (3 ft) or any part of the sign.
- 3.8.5 Sign Orientation At an angle of not less than 30 degrees and not more than 45 degrees to a line parallel to the flow of traffic.
- 3.8.6 Visibility The property owner is responsible to ensure that physical obstructions are not placed or constructed in locations that interfere with the visibility and/or legibility of any Fire Route sign and to ensure sufficient maintenance of vegetation such that unobstructed views to all Fire Route signs are maintained at all times and under all circumstances.
- 3.8.7 Sign Post Type and material as described in Schedule "B" attached hereto and forming part of this By-law
- 3.8.8 Sign Type Type and material as described in Schedule "C" attached hereto and forming part of this By-law

4. ADMINISTRATION AND ENFORCEMENT

- 4.1 This by-law shall apply to all lands indicated in Schedule "A" attached hereto and forming part of this By-law.
- 4.2 Every person who contravenes any of the provisions of this by-law is guilty of an offence and upon conviction, is liable to a fine or penalty as provided in the Provincial Offences Act.

READ A FIRST, SECOND AND THIRD TIME THIS 5th DAY OF JUNE, 1996.

SEAL

"Original Signed by David Oliphant"
David Oliphant, Mayor

"Original Signed by Jeff Carswell"
Jeff Carswell, Clerk

SCHEDULE "A"

DESIGNATED FIRE ROUTES

<u>LOCATION</u>	<u>ADDRESS</u>
Tolgate School East driveway from road to principal entrance - 36m length	Con 11, E Pt. Lot 6 R.R.# 6, Woodstock On N4S 7W1
Innerkip Central School Consists of total driveway in front of primary school entrance	180 Coleman Street, Innerkip Plan 241, Lot 1, S. Pt Lot 2
Innerkip Community Centre South driveway and total frontage of building	Con 17, W Pt. Lot 10 41R1580 Part 1 R.R. # 1, Innerkip On N0J 1M0
Innerkip Seniors Apartments Laneway from from road leading to primary entrance along curb/grass area	Plan 111 Lots 99-104, 130-132 30 Balsam Street
Hickson Central School Main driveway and front entrance area leading to street	161 Loveys Street E, Hickson Plan 820 Lot 41, Pt Lot 60
The Renaissance Front driveway and drop-off area to a depth of 30m from streetline	199 Hope Street E., Tavistock Condo Plan 35
Maples Home for Seniors North entrance full width of driveway from sidewalk to grass area a building	94 William Street S, Tavistock Plan 307, Pt. Block A
East Zorra-Tavistock Arena North side of property using existing driveway in Queen's Park	1 Adam Street, Tavistock Plan 307, Lot 24 Reg Comp Plan 1609, Lot 24, Pt. Lot 25
Tavistock Public School Driveway along south side of building to rear corner and driveway along front of building	79 Maria Street, Tavistock, Ontario N0B 2R0

<u>LOCATION</u>	<u>ADDRESS</u>
Village Manor East entrance and driveway to main entrance including circular drive	198 Woodstock Street S, Tavistock, Ontario N0B 2R0
<i>By-law #2006-41</i> Innerkip Presbyterian Church <ul style="list-style-type: none">• North and south entrances and driveway to main building entrance• Driveways along the north and south side of the building to the rear of the building	64 Blandford Street, Innerkip

SCHEDULE "B"

SIGN POST DETAILS

Sign Posts shall conform to OPSS 2005 - Material Specification for Steel "U" Flanged Sign Post & Spacer.

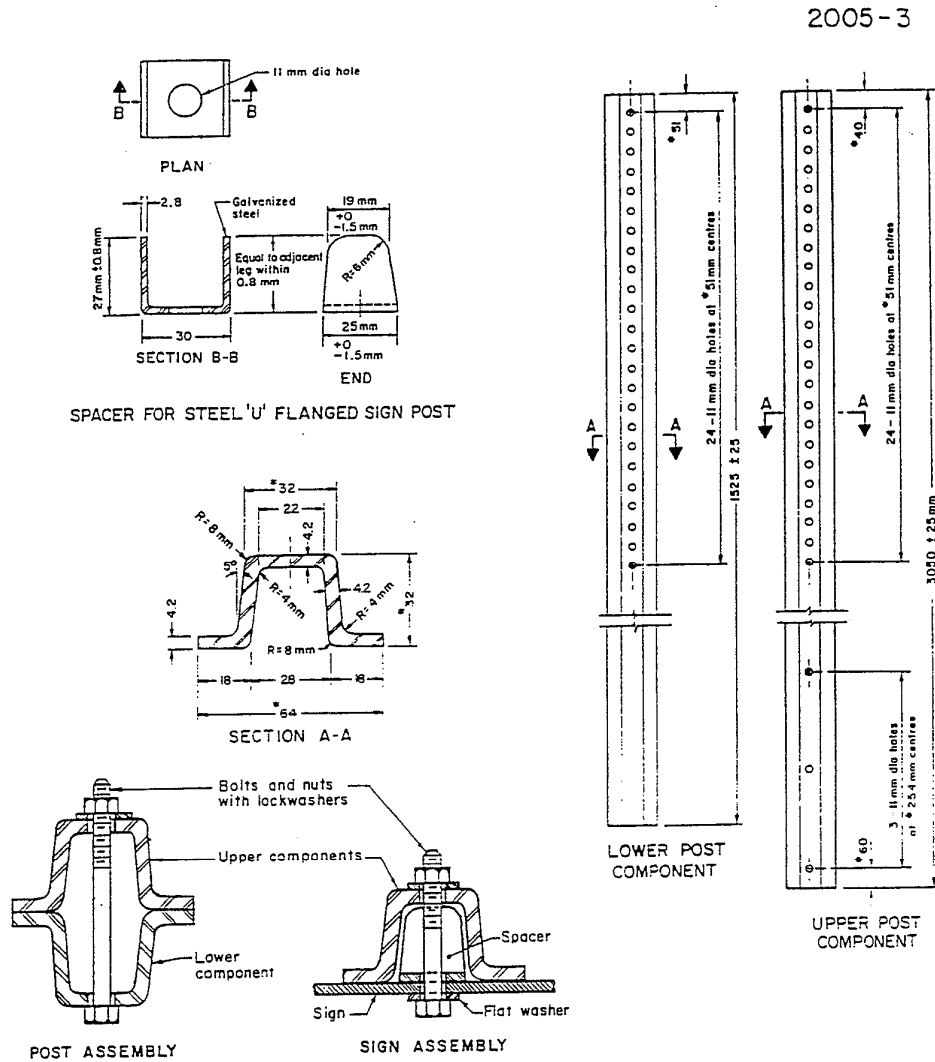

NOTES:

- A Tolerances:
 Dimensions with asterisk (*) ±1.6 mm
 Thickness ±0.381 mm
 All other dimensions ±0.8 mm.
- B All dimensions are in millimetres unless otherwise shown.

**STEEL 'U' FLANGED
SIGN POST AND SPACER**

N.T.S.

FIG. 1

SCHEDULE "C"

SIGN DETAILS

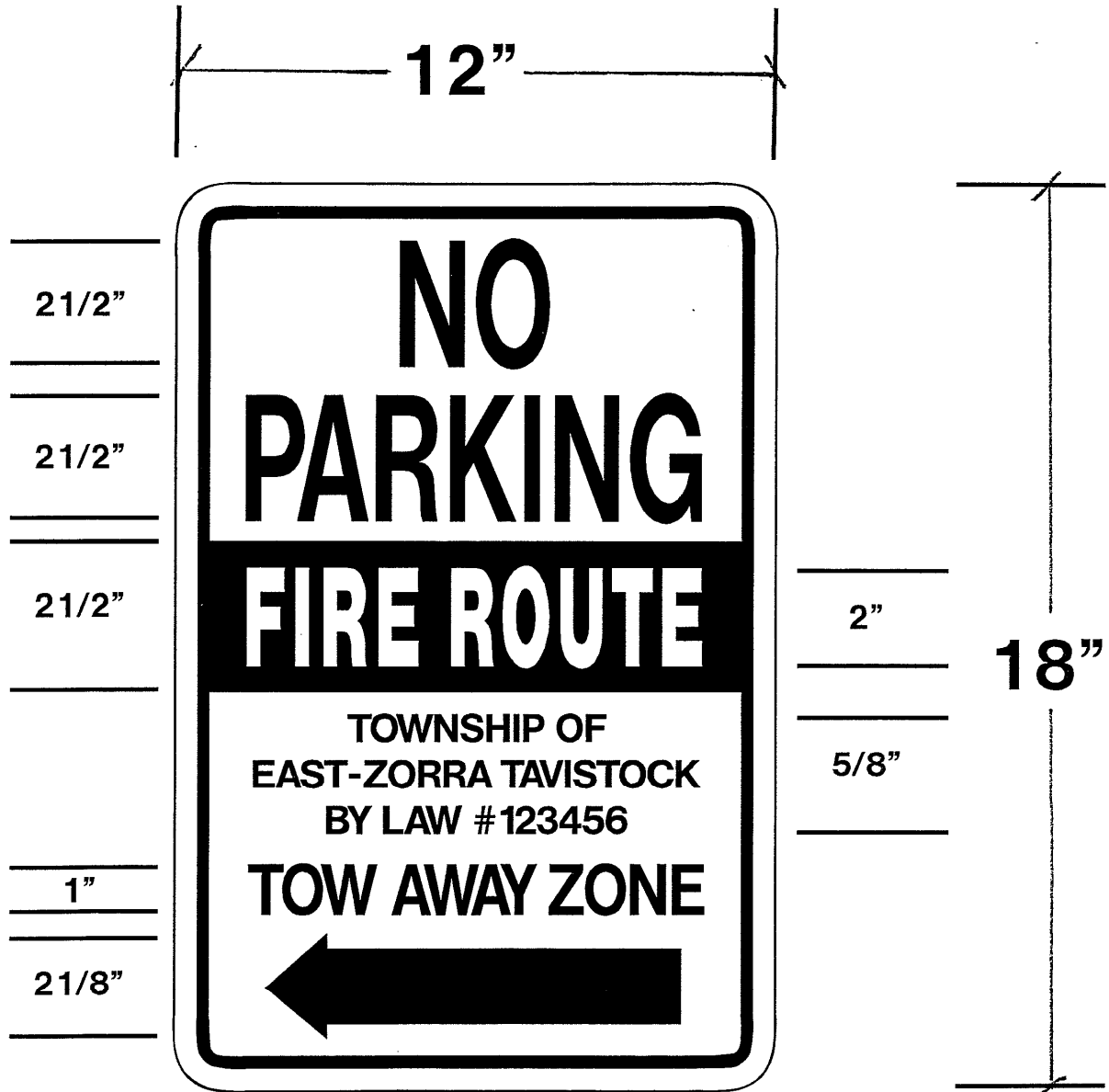

1/4" BORDER OUTLINE